

両斜壁

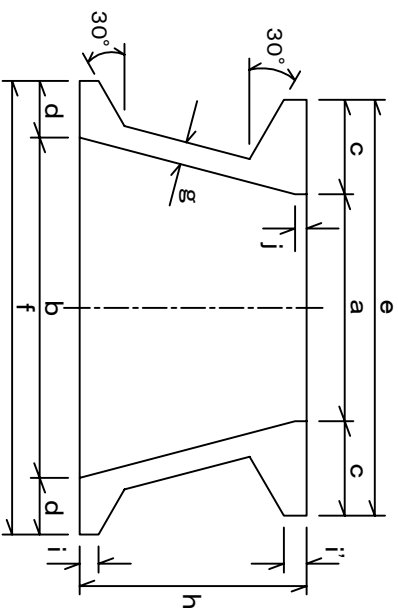

直壁

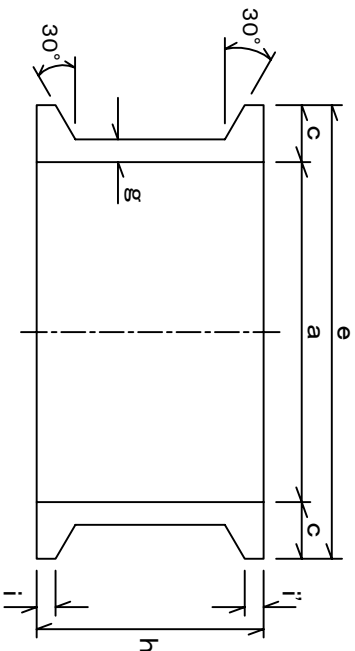

片斜壁

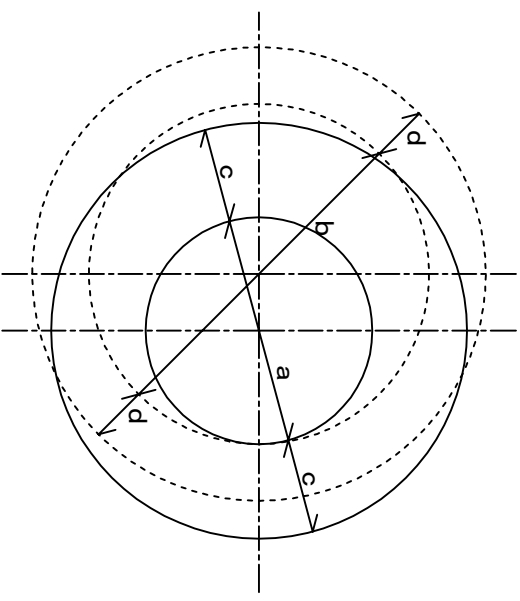
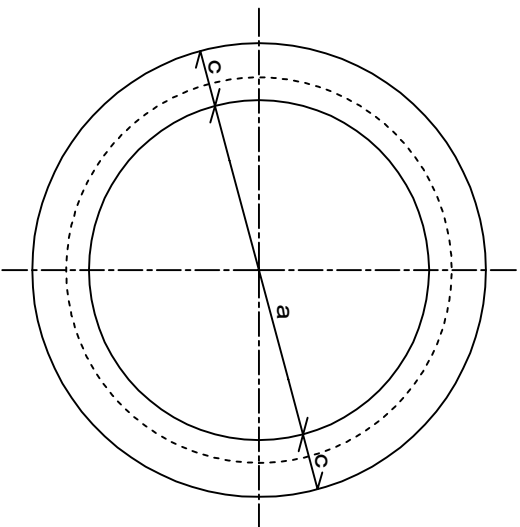
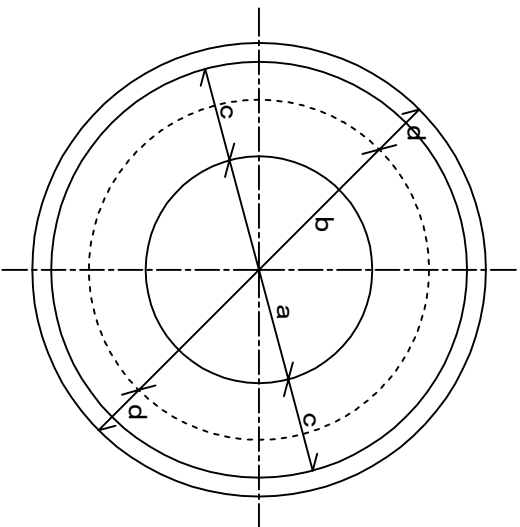
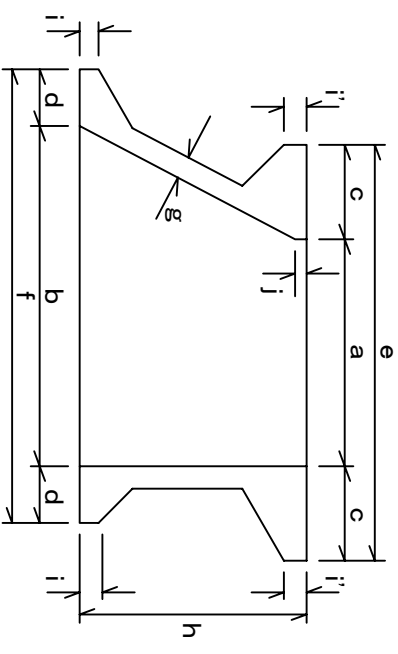

呼び名	寸法(mm)											参考重量(kg)
	a	b	c	d	e	f	g	h	i	i'	j	
600A	600	900	250	150	1100	1200	60	300	50	60	30	324
600B	600	900	250	150	1100	1200	60	450	50	60	30	377
600C	600	900	250	150	1100	1200	60	600	50	60	30	432
600D	600	1200	250	150	1100	1500	70	600	50	60	40	551

呼び名	寸法(mm)											参考重量(kg)
	a	b	c	d	e	f	g	h	i	i'	j	
900A	900	-	150	-	1200	-	60	300	50	50	-	249
900B	900	-	150	-	1200	-	60	600	50	50	-	382
1200A	1200	-	150	-	1500	-	70	300	50	50	-	332
1200B	1200	-	150	-	1500	-	70	600	50	50	-	538
1500A	1500	-	150	-	1800	-	80	300	50	50	-	422
1500B	1500	-	150	-	1800	-	80	600	50	50	-	714

呼び名	寸法(mm)											参考重量(kg)
	a	b	c	d	e	f	g	h	i	i'	j	
600A	600	900	250	150	1100	1200	60	300	50	60	30	322
600B	600	900	250	150	1100	1200	60	450	50	60	30	373
600C	600	900	250	150	1100	1200	60	600	50	60	30	439
600D	600	1200	250	150	1100	1500	70	600	50	60	30	600

※足掛金物を設置可能